

NEMA

MOTOR MODEL:	BK3-CI-TF-256T-6-BR-G-10
FACTORY TYPE:	-

NEMA Cast Iron, TEFC

ELECTRICAL DATA		
	60 Hz	50 Hz
Horsepower	10.0	-
Speed, RPM	1138	-
Voltage	230/460/796	-
# Phase	-	
Full Load Amps	26/13/7.5	-
Power Factor	0.83	3.0
Nominal Efficiency	87.0	-
3/4 Load Efficiency	-	-
Service Factor	1.15	-
KVA Code	G	-
FL Amps. @ 208 V	-	-
LRC @ 60Hz HV	83.9	-
Start Capacitor	-	
Start Capacitor V	-	
Run Capacitor	-	
Run Capacitor V	-	
Number of Leads	12	
Connection	-	
Coil Resistance	-	
Date Code	-	
Load	Efficiency %	P.F.
50%	86.21	0.6675
75%	86.78	0.7668
100%	85.43	0.8096
FULL LOAD TEMPERATURE RISE		
FL Temp Rise °C	-	
3D Image Link		
Not available for this motor		

GENERAL DATA		
Frame Size	286T	
Frame Enclosure	TEFC	
Mounting	Rigid	
Insulation Class	F	
Duty	-	
NEMA Design	D	
Frame Material	Cast Iron	
Ingress Protection	55	
Tropicalization	-	
Cable Entry	-	
Feet Removable	-	
Double Drilled	-	
Paint Color	-	
Paint RAL	-	
Weight lb	-	
MECHANICAL DATA		
DE Bearing	6309C3	
NDE Bearing	6309C3	
dB No-Load	-	
Rotor Wk ² , Lb-Ft ²	-	
Comp Ring (wavy washer)	-	
TORQUE VALUES	Torque lb-ft	% FLT
Locked Rotor Torque	125.81	267.0
Pull-Up Torque	97.71	208.0
Breakdown Torque	118.36	352.0
Full Load Torque	47.05	100.0
SITE CONDITIONS		
Ambient Temp °C	-	
Altitude Above Sea Level m	-	

*This report valid for above Date Code and newer models, please contact Techttop for more info.



Pump Motors

NEMA

MOTOR MODEL:	BK3-CI-TF-256T-6-BR-G-10
FACTORY TYPE:	-

NEMA Cast Iron, TEFC

Torque Speed (T-n) Curve

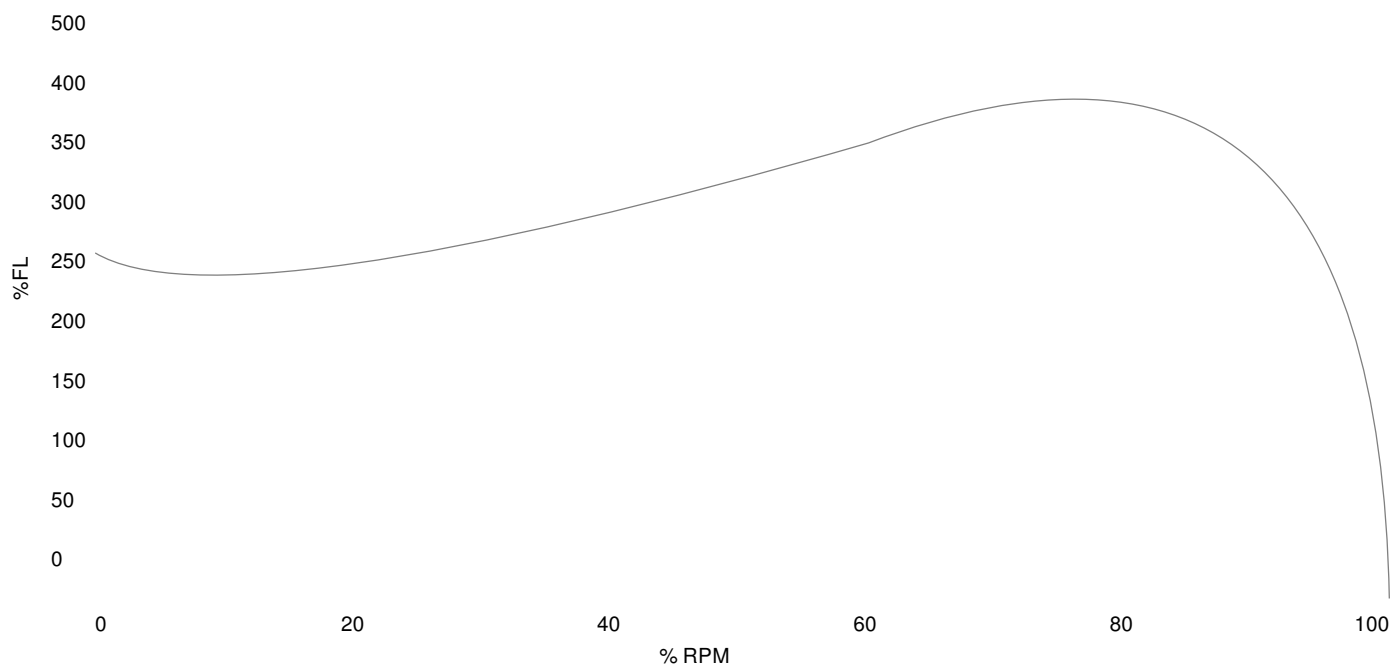

Performance Load Values, High Voltage, 60Hz

Torque Values	Torque lb-ft	% FLT	Performance Values
Locked Rotor Torque	125.81	267.0	Start Configuration
Pull-Up Torque	97.71	208.0	Starting Current (A)
Breakdown Torque	118.36	352.0	No-Load Current (A)
Full Load	47.05	100.0	No-Load Power Factor

% Load	Horsepower	Current, Amps	Input power, Kilowatts	Speed, RPM	Efficiency	PF
0	0.0	6.222	0.3998	1198.0	0.0	0.081
25	2.5	6.331	2.334	1181.2	80.33	0.4627
50	5.0	8.179	4.35	1166.1	86.21	0.6675
75	7.5	10.61	6.482	1146.5	86.78	0.7668
100	10.0	13.61	8.779	1122.4	85.43	0.8096
125	12.5	17.2	11.297	1093.8	82.99	0.8244

Techtop Industries
 2815 Colonnades Court
 Peachtree Corners, GA 30071
 Tel: 678-436-5540
 E-Mail: info@techttopind.com