

Techtop Industries Nameplate and Performance Data

NAMEPLATE DATA		
	60 Hz.	50 Hz.
Horsepower	75.0	-
Frame Size	365TC	
Speed, RPM	1775	1465
Voltage	3 Phase US	380
# Phase	3	
Full Load Amps	86.2	-
Power Factor	0.87	-
Nominal Efficiency	95.4	-
3/4 Load Efficiency	-	-
Service Factor	1.15	1.0
Duty	Cont. / S1	
FL Temp Rise °C	62.0	88.0
Enclosure	TEFC	
Ambient Temp °C	40	
KVA Code	F	F
FL Amps. @ 208 V	-	-
Insulation Class	F	
NEMA Design	B	
Weight	904.0	
DE Bearing	6313C3	
NDE Bearing	6313C3	
dB No-Load	90.0	
Rotor Wk ² , Lb-Ft ²	0.8004	
Start Capacitor	-	
Start Capacitor V	-	
Run Capacitor	-	
Run Capacitor V	-	
Number of Leads	6	
Connection	?	
Coil Resistance	-	

Motor Model:	BR3-CI-TF-365TC-4-BR-E-75
---------------------	----------------------------------

Performance Load Values:

% Load	Horsepower	Current, Amps	Input power, Kilowatts	Speed, RPM	Efficiency	PF
0	-	-	-	-	-	-
25	-	-	-	-	-	-
50	-	-	-	-	94.8	0.77
75	-	-	-	-	95.2	0.85
100	-	-	-	-	95.4	0.87
125	-	-	-	-	-	-
150	-	-	-	-	-	-
SF	-	-	-	-	-	-

	Torque, Lb-Ft	% Full Load Torque	Speed, RPM	Current Amps.
Locked Rotor Torque	624.21	280.0	-	-
Pull Up Torque	356.691	160.0	-	-
Breakdown Torque	824.849	370.0	-	-
Full Load	222.932	100.0	-	-

Speed Torque Curve

Please contact Techtop for image.

Dimensional Drawing

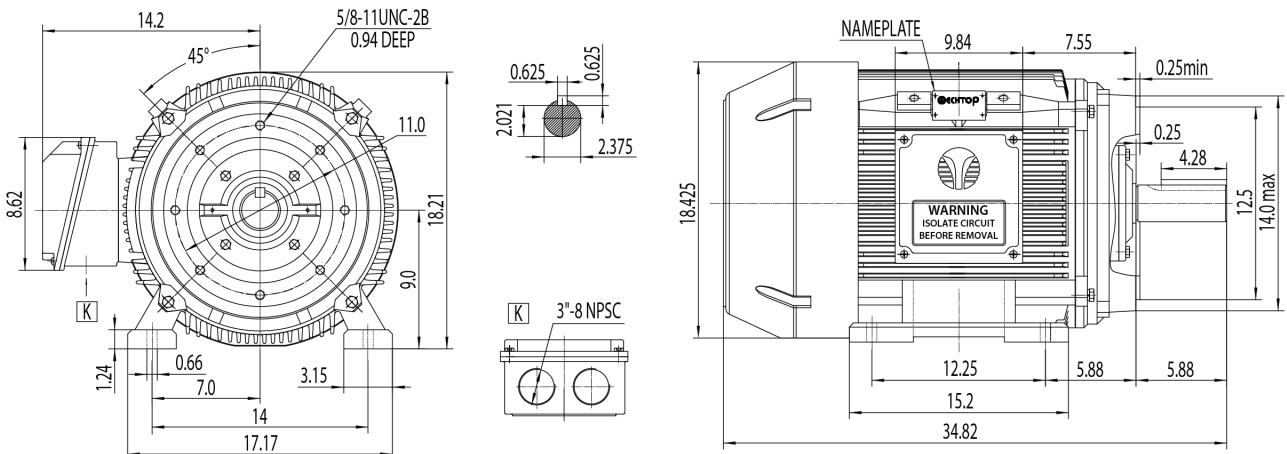

Dimensions are for reference only. Allowance should be made for minor deviations in non standard specified properties.

3D Image Link: Not available for this motor