

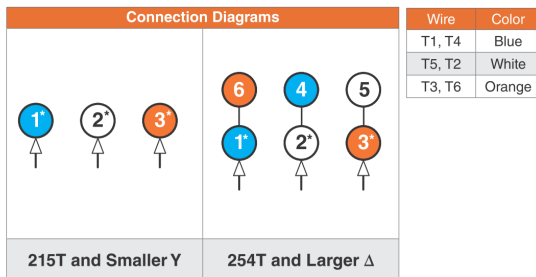

<b>MOTOR MODEL:</b>	GR3-CI-TF-143T-2-B-F-1
<b>FACTORY TYPE:</b>	TXC

## Premium NEMA Cast Iron, TEFC

### 3 Phase NEMA Single Voltage 575V or 460V



When motor is in F1 position, leads shown with "\*" exit the casing above the center line of the motor, the remaining leads exit below the center line. This information can be used to identify missing or mislabelled leads.

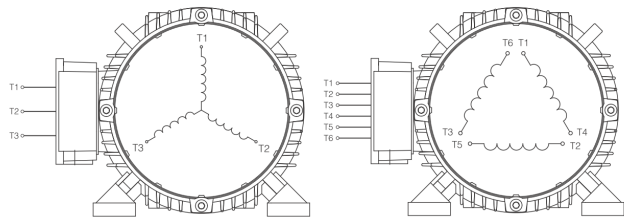

<b>MOTOR MODEL:</b>	GR3-CI-TF-143T-2-B-F-1
<b>FACTORY TYPE:</b>	TXC

**NEMA**

Premium NEMA Cast Iron, TEFC

