



NEMA Premium

NEMA

MOTOR MODEL:	GR3-CI-TF-215T-2-B-D-10
FACTORY TYPE:	TXC

Premium NEMA Cast Iron, TEFC

ELECTRICAL DATA		
	60 Hz	50 Hz
Horsepower	10.0	10.0
Speed, RPM	3520	2910
Voltage	230/460	190/380
# Phase	3	
Full Load Amps	22.57/11.28	31/15.5
Power Factor	0.89	-
Nominal Efficiency	90.2	87.0
3/4 Load Efficiency	-	-
Service Factor	1.25	1.0
KVA Code	K	H
FL Amps. @ 208 V	24.9529	-
LRC @ 60Hz HV	239.516	-
Start Capacitor	-	
Start Capacitor V	-	
Run Capacitor	-	
Run Capacitor V	-	
Number of Leads	9	
Connection	YY/Y	
Coil Resistance	-	
Date Code	-	
Load	Efficiency %	P.F.
50%	-	-
75%	-	-
100%	-	-
FULL LOAD TEMPERATURE RISE		
FL Temp Rise °C	-	-
3D Image Link		
GR3-CI-TF-215T-2-B-D-10		

GENERAL DATA			
Frame Size	215T		
Frame Enclosure	TEFC		
Mounting	Rigid		
Insulation Class	F		
Duty	Cont. / S1		
NEMA Design	A		
Frame Material	Cast Iron		
Ingress Protection	55		
Tropicalization	true		
Cable Entry	1-NPT 1"		
Feet Removable	true		
Double Drilled	-		
Paint Color	Graphite Gray		
Paint RAL	7024		
Weight lb	165.375		
MECHANICAL DATA			
DE Bearing	6308ZZ		
NDE Bearing	6308ZZ		
dB No-Load	-		
Rotor Wk ² , Lb-Ft ²	-		
Comp Ring (wavy washer)	NDE		
TORQUE VALUES		Torque lb-ft	% FLT
Locked Rotor Torque		42.4348	283.0
Pull-Up Torque		6.44769	43.0
Breakdown Torque		67.9257	453.0
Full Load Torque		14.9946	100.0
SITE CONDITIONS			
Ambient Temp °C		40	
Altitude Above Sea Level m		1000	

*This report valid for above Date Code and newer models, please contact Techtop for more info.

Techtop Industries
2815 Colonnades Court
Peachtree Corners, GA 30071
Tel: 678-436-5540
E-Mail: info@techttopind.com



NEMA Premium

NEMA

MOTOR MODEL:	GR3-CI-TF-215T-2-B-D-10
FACTORY TYPE:	TXC

Premium NEMA Cast Iron, TEFC

Torque Speed (T-n) Curve

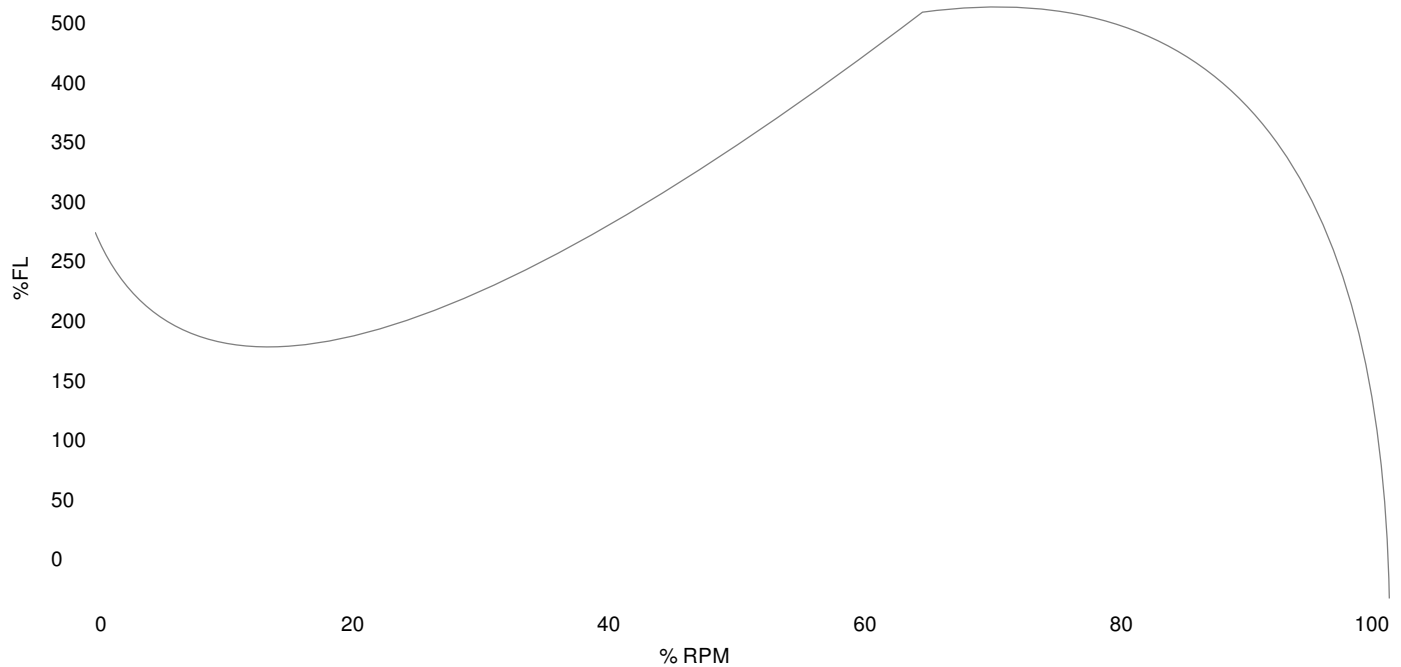

Performance Load Values, High Voltage, 60Hz

Torque Values	Torque lb-ft	% FLT	Performance Values
Locked Rotor Torque	42.4348	283.0	Start Configuration
Pull-Up Torque	6.44769	43.0	Starting Current (A)
Breakdown Torque	67.9257	453.0	No-Load Current (A)
Full Load	14.9946	100.0	No-Load Power Factor

% Load	Horsepower	Current, Amps	Input power, Kilowatts	Speed, RPM	Efficiency	PF
0	-	-	-	-	-	-
25	2.5	-	-	-	-	-
50	5.0	-	-	-	-	-
75	7.5	-	-	-	-	-
100	10.0	-	-	-	-	-
125	12.5	-	-	-	-	-

Techtop Industries
 2815 Colonnades Court
 Peachtree Corners, GA 30071
 Tel: 678-436-5540
 E-Mail: info@techttopind.com