





NEMA Premium

**NEMA**

<b>MOTOR MODEL:</b>	GR3-CI-TF-284TS-2-BR-F-25
<b>FACTORY TYPE:</b>	TXC

Premium NEMA Cast Iron, TEFC

Torque Speed (T-n) Curve

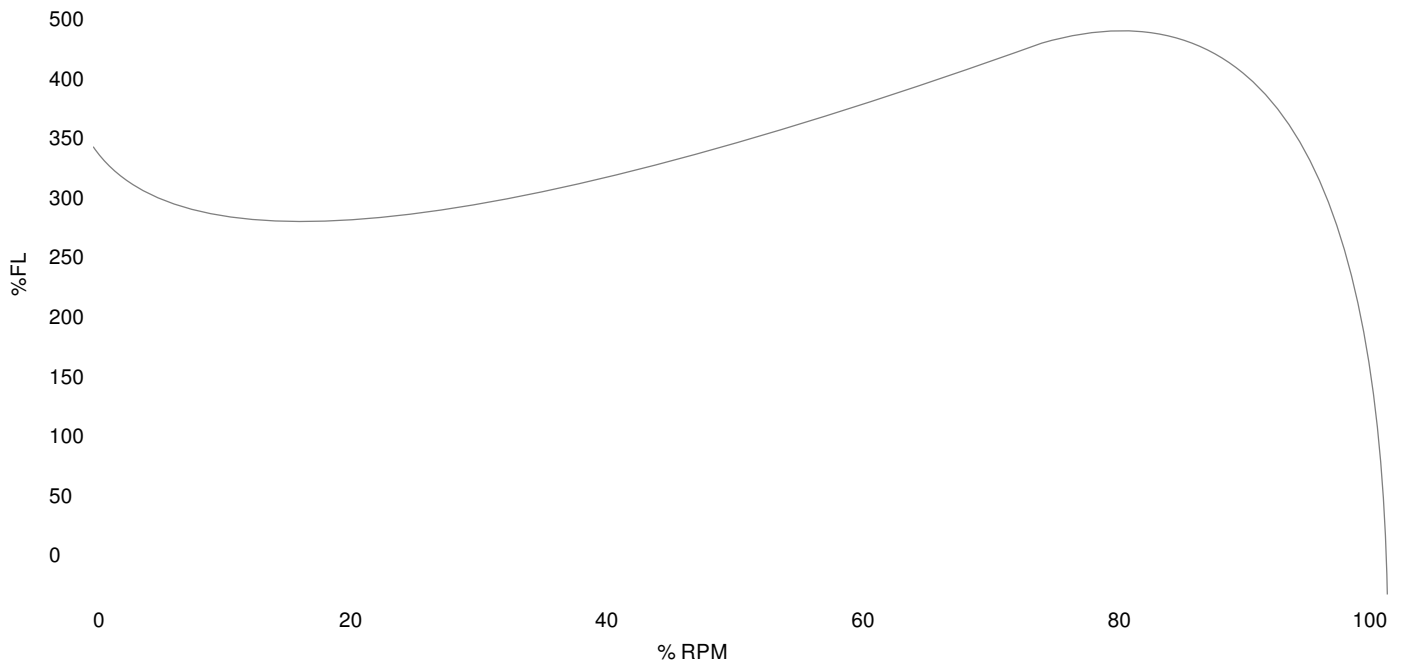

Performance Load Values, High Voltage, 60Hz

Torque Values	Torque lb-ft	% FLT	Performance Values
Locked Rotor Torque	127.93	346.0	Start Configuration
Pull-Up Torque	73.5782	199.0	Starting Current (A)
Breakdown Torque	157.509	426.0	No-Load Current (A)
Full Load	36.974	100.0	No-Load Power Factor

% Load	Horsepower	Current, Amps	Input power, Kilowatts	Speed, RPM	Efficiency	PF
0	-	12.34	-	-	-	-
25	6.25	13.71	5.6	3591.4	83.02	0.51
50	12.5	18.36	10.39	3582.8	89.54	0.71
75	18.75	23.72	15.26	3573.7	91.42	0.81
100	25.0	29.67	20.23	3564.1	91.96	0.86
125	31.25	36.11	25.3	3554.1	91.91	0.88

Techtop Industries  
 2815 Colonnades Court  
 Peachtree Corners, GA 30071  
 Tel: 678-436-5540  
 E-Mail: info@techttopind.com