



Farm Duty

NEMA

| | |
|----------------------|-------------------------|
| MOTOR MODEL: | RD1-RS-TF-215T-4-B-B-10 |
| FACTORY TYPE: | SLF |

NEMA Rolled Steel, TEFC

| ELECTRICAL DATA | | |
|---|---------------------|-------------|
| | 60 Hz | 50 Hz |
| Horsepower | 10.0 | - |
| Speed, RPM | 1740 | - |
| Voltage | 208-230 | - |
| # Phase | 1 | |
| Full Load Amps | 46.3-41.8 | - |
| Power Factor | 0.94 | - |
| Nominal Efficiency | 83.0 | - |
| Service Factor | 1.15 | - |
| KVA Code | H | - |
| FL Amps. @ 208 V | 46.3 | - |
| LRC @ 60Hz HV | 299.932 | - |
| Start Capacitor | 500 x2 | |
| Start Capacitor V | 350 | |
| Run Capacitor | 50 x2 | |
| Run Capacitor V | 450 | |
| Number of Leads | 5 | |
| Connection | - | |
| Coil Resistance | - | |
| Date Code | - | |
| | | |
| Load | Efficiency % | P.F. |
| 50% | - | - |
| 75% | - | - |
| 100% | - | - |
| | | |
| FULL LOAD TEMPERATURE RISE | | |
| FL Temp Rise °C | 93.0 | - |
| | | |
| 3D Image Link | | |
| RD1-RS-TF-215T-4-B-B-10 | | |

| GENERAL DATA | | | |
|--|---------------|--------------|-------|
| Frame Size | 215T | | |
| Frame Enclosure | TEFC | | |
| Mounting | Rigid | | |
| Insulation Class | F | | |
| Duty | Cont. / S1 | | |
| NEMA Design | L | | |
| Frame Material | Rolled Steel | | |
| Ingress Protection | 54 | | |
| Tropicalization | true | | |
| Cable Entry | 1.1" | | |
| Feet Removable | - | | |
| Double Drilled | true | | |
| Paint Color | Graphite Gray | | |
| Paint RAL | 7024 | | |
| Weight lb | 207.0 | | |
| | | | |
| MECHANICAL DATA | | | |
| DE Bearing | 6208-2RZ | | |
| NDE Bearing | 6206-2RZ | | |
| dB No-Load | - | | |
| Rotor Wk ² , Lb-Ft ² | - | | |
| Comp Ring (wavey washer) | NDE | | |
| | | | |
| TORQUE VALUES | | Torque lb-ft | % FLT |
| Locked Rotor Torque | 108.962 | 362.0 | |
| Pull-Up Torque | 58.9958 | 196.0 | |
| Breakdown Torque | 68.0258 | 226.0 | |
| Full Load Torque | 30.0999 | 100.0 | |
| | | | |
| SITE CONDITIONS | | | |
| Ambient Temp °C | 40 | | |
| Altitude Above Sea Level m | 1000 | | |

*This report valid for above Date Code and newer models, please contact Techttop for more info.



Farm Duty

NEMA

| | |
|----------------------|-------------------------|
| MOTOR MODEL: | RD1-RS-TF-215T-4-B-B-10 |
| FACTORY TYPE: | SLF |

NEMA Rolled Steel, TEFC

Torque Speed (T-n) Curve

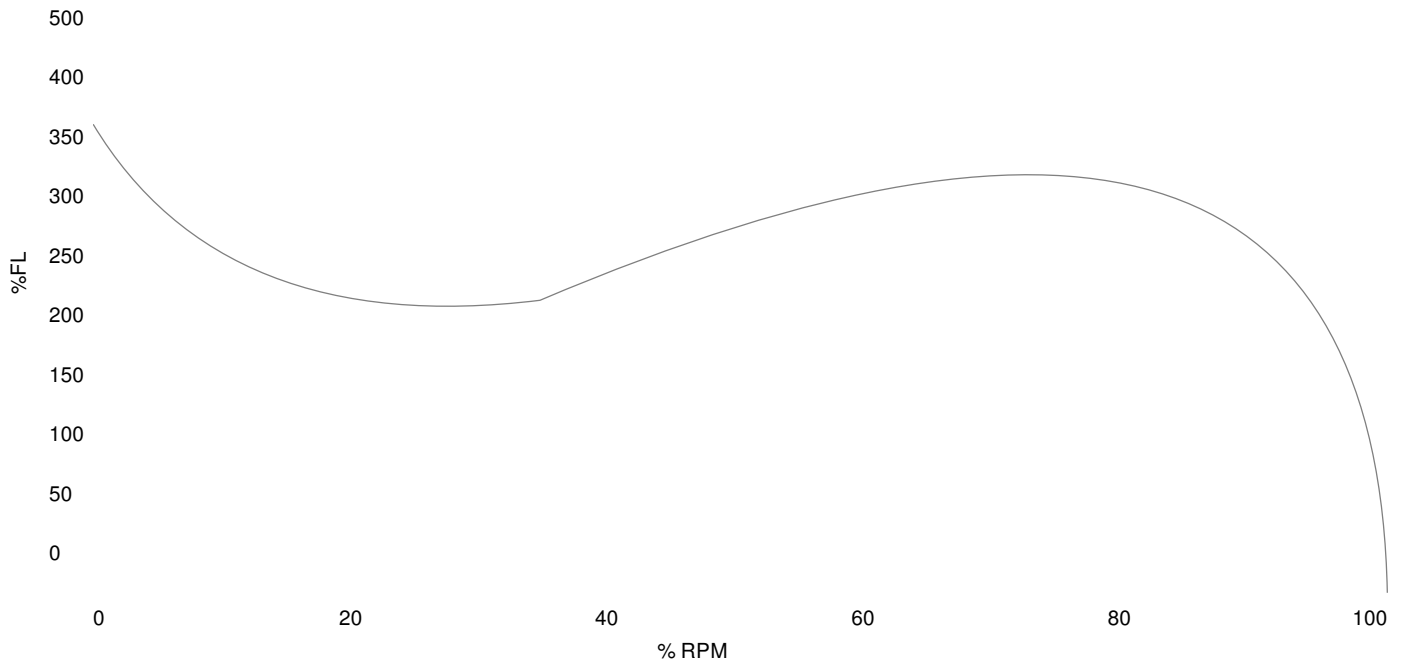

Performance Load Values, High Voltage, 60Hz

| Torque Values | Torque lb-ft | % FLT | Performance Values |
|---------------------|--------------|-------|----------------------|
| Locked Rotor Torque | 108.962 | 362.0 | Start Configuration |
| Pull-Up Torque | 58.9958 | 196.0 | Starting Current (A) |
| Breakdown Torque | 68.0258 | 226.0 | No-Load Current (A) |
| Full Load | 30.0999 | 100.0 | No-Load Power Factor |

| % Load | Horsepower | Current, Amps | Input power, Kilowatts | Speed, RPM | Efficiency | PF |
|--------|------------|---------------|------------------------|------------|------------|----|
| 0 | - | - | - | - | - | - |
| 25 | - | - | - | - | - | - |
| 50 | - | - | - | - | - | - |
| 75 | - | - | - | - | - | - |
| 100 | - | - | - | - | - | - |
| 125 | - | - | - | - | - | - |

Techtop Industries
 2815 Colonnades Court
 Peachtree Corners, GA 30071
 Tel: 678-436-5540
 E-Mail: info@techttopind.com

| | |
|----------------------|-------------------------|
| MOTOR MODEL: | RD1-RS-TF-215T-4-B-B-10 |
| FACTORY TYPE: | SLF |

NEMA Rolled Steel, TEFC

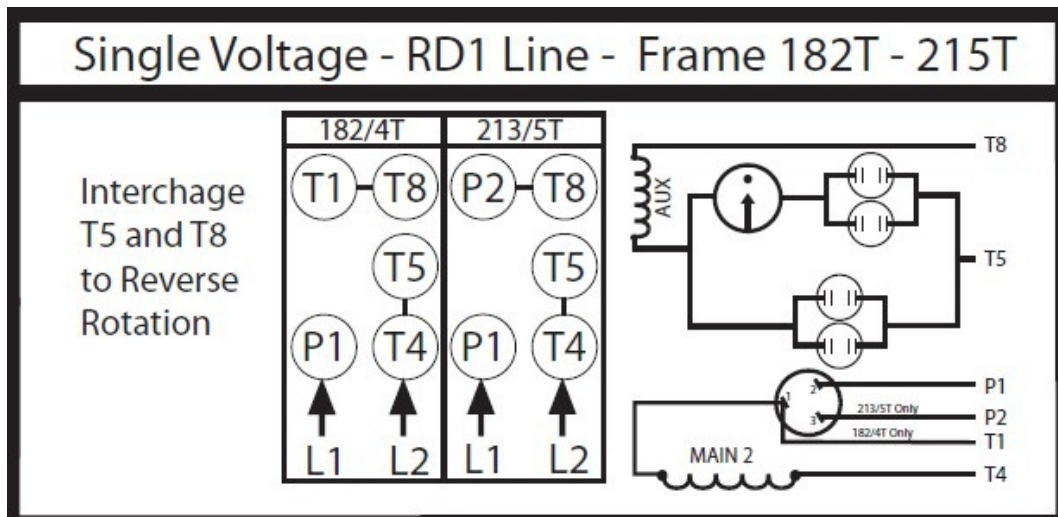

| | |
|----------------------|-------------------------|
| MOTOR MODEL: | RD1-RS-TF-215T-4-B-B-10 |
| FACTORY TYPE: | SLF |

NEMA Rolled Steel, TEFC

